

FEA

OPTI-FET COMPRESSOR



About the design:

The FEA OPTI-FET Compressor is designed with both audiophile and studio quality features that many musicians enjoy.

The audio path for the signal is a 100% “class A” discrete design containing no op-amps and features a passive gain reduction element. The FET (Field Effect Transistor) amplifier is popular in the audiophile community for having some of the classic sonic qualities of a tube amplifier. There are many concepts of signal amplification design that audiophiles desire and debate over. One of the more popular audiophile designs (using solid state circuitry) is for a minimum or zero feedback discrete “class A” FET amplifier circuit. The FEA OPTI-FET Compressor utilizes this circuit design in the final output amplifier stage. The input amplifier stage is a high impedance “class A” FET buffer amplifier design. The amplifier buffer has been designed to have minimal signal distortion and maximum headroom for all input signal levels.

Another feature in the FEA OPTI-FET Compressor is the extensive side-chain control which is not commonly found in most pedal type compressors today. Like many quality studio rack compressors, the OPTI-FET compressor has all of the common controls available to the user to accurately shape his or her tone. Along with the full feature set of side-chain controls a three band equalizer is available. This EQ only affects the amplitude of frequencies of the signal in the compressor control circuits. This allows the user to adjust the frequencies they want to apply more or less compression upon. The OPTI-FET compressor also has a side-chain loop feature, similar to many rack compressors. This allows the user to be more creative with the use of other outboard pedals. Multi-band EQ, or buffered volume pedals are a few that can make this pedal even more versatile when used in the side-chain loop.

The Silonex AOI's (analog optical isolators) used in the FEA OPTI-FET Compressor utilize a combination formula for the photocell to overcome limitations found in other traditional optical components affecting reaction and recovery times. This fast current monitored Silonex AOI allows the side-chain in the compressor to accurately control the dynamics of the compression. The purely resistive photo element in the AOI exhibits less noise and distortion than most designs using a VCA (voltage controlled amplifier). A good number of audiophiles advocate that only high-quality passive components should be in the audio signal path and this is one application that I would have to agree with them.

Along with these fantastic Silonex AOI's, the FEA OPTI-FET Compressor utilizes 1% metal film resistors, multi-layer metallized polyester film capacitors, and low noise audiophile grade transistors in the signal path.

The dual rail power supply in the OPTI-FET Compressor is built on an isolated circuit board. The power supply can be powered with 9 to 25V DC and is over filtered two times to assure exceptionally clean power for the signal circuitry. This power supply provides 18Volts (+9V and -9V) to the compressor circuit board to provide plenty of headroom for the signal. The power supply was designed to provide separate power for all of the side-chain control circuitry. This assures that any natural electrical noise that the compressor side-chain control circuitry generates will not bleed into the signal circuitry. I have not seen this approach to power distribution in any of the other manufacturer's guitar effects. Is it overkill? Maybe...but I feel that it is absolutely crucial to eliminate every bit of noise where possible.

The case is a standard Hammond aluminum enclosure. After the Hammond case is CNC machined and sanded it is then professionally color powder coated. The aluminum faceplate is then applied and then the entire case is clear epoxy powder coated for protection.

Frank E. Appleton (FEA)

Features:

- **THRESHOLD, RATIO, ATTACK, RELEASE and GAIN controls.** The control ranges for the **ATTACK** and **RELEASE** have been optimized for use on both bass and guitar.
- The compressor exhibits soft-knee compression at lower **RATIO** settings and hard-knee at maximum **RATIO** settings. The **COMP LED** indicates when the **THRESHOLD** has been reached. This LED does not indicate the **RELEASE** response.
- The compressor side-chain utilizes precision full-wave rectification of the audio signals in the **THRESHOLD** circuit to improve tracking. This also reduces the possibility of “pumping” with very low frequencies.
- **ACTIVATE** foot switch places the compressor unit in the signal chain or in **Direct Bypass** mode. In **Direct Bypass** mode the signal at the input is directly connected to the output and does not pass through any electronics.
- **EQUALIZER** foot switch enables the three band equalizer controls for the side-chain control circuit. The three band EQ only affects the amplitude of frequencies of the signal in the side-chain control circuit.
- **LOOP SEND/RETURN** jacks are for placing external processors or EQ's in the compressor side-chain control circuit. These jacks are only active when the **EQUALIZER** foot switch is enabled.
- The compressor has minimal components in the signal path to maintain the utmost signal quality. The signal compression is accomplished with only a resistive component (Light Dependent Resistor or Photocell). All resistors in the circuit are low noise 1% metal film type. The signal coupling capacitors are tight tolerance, quiet, multi-layer and metallized polyester film type. The transistors utilized in the signal path are popular low noise audiophile grade devices.
- The power supplies onboard voltage charge pump allows the circuitry to operate at 18volts (+9 and -9 volt rails) from a single 9-volt battery or AC power adapter of 9 volts or greater. This allows the signal plenty of headroom from active electronic guitars and aggressive playing techniques (i.e. pop and slap).
- The onboard power supply can accommodate power adapter voltages up to 25 volts DC with protection from reversed polarity. The “switch on” power supply current is less than 1 μ A (micro amp) on the signal ground at the **INPUT** jack. This is approximately 45,000 times (-93dB) less than the commonly used method of connecting the battery's negative terminal to ground via the sleeve of the plug inserted into the **INPUT** jack. The “switch on” sensing method used in the **FEA OPTI-FET Compressor** keeps nearly all of the circuit's generated white noise and transient currents out of the **INPUT** stage signal ground. Extreme measures have been taken to keep the power and signal paths as clean as possible. **NOTE: Unplug the cord from the INPUT jack when not in use to prolong battery life.**
- The power and grounds for the signal path circuitry are separated from the side-chain power and grounds to protect the audio signal from spurious noise. The power for the signal amplifiers is exceptionally clean, filtered twice for each rail and all filter stages are oversized.

Block Diagram:

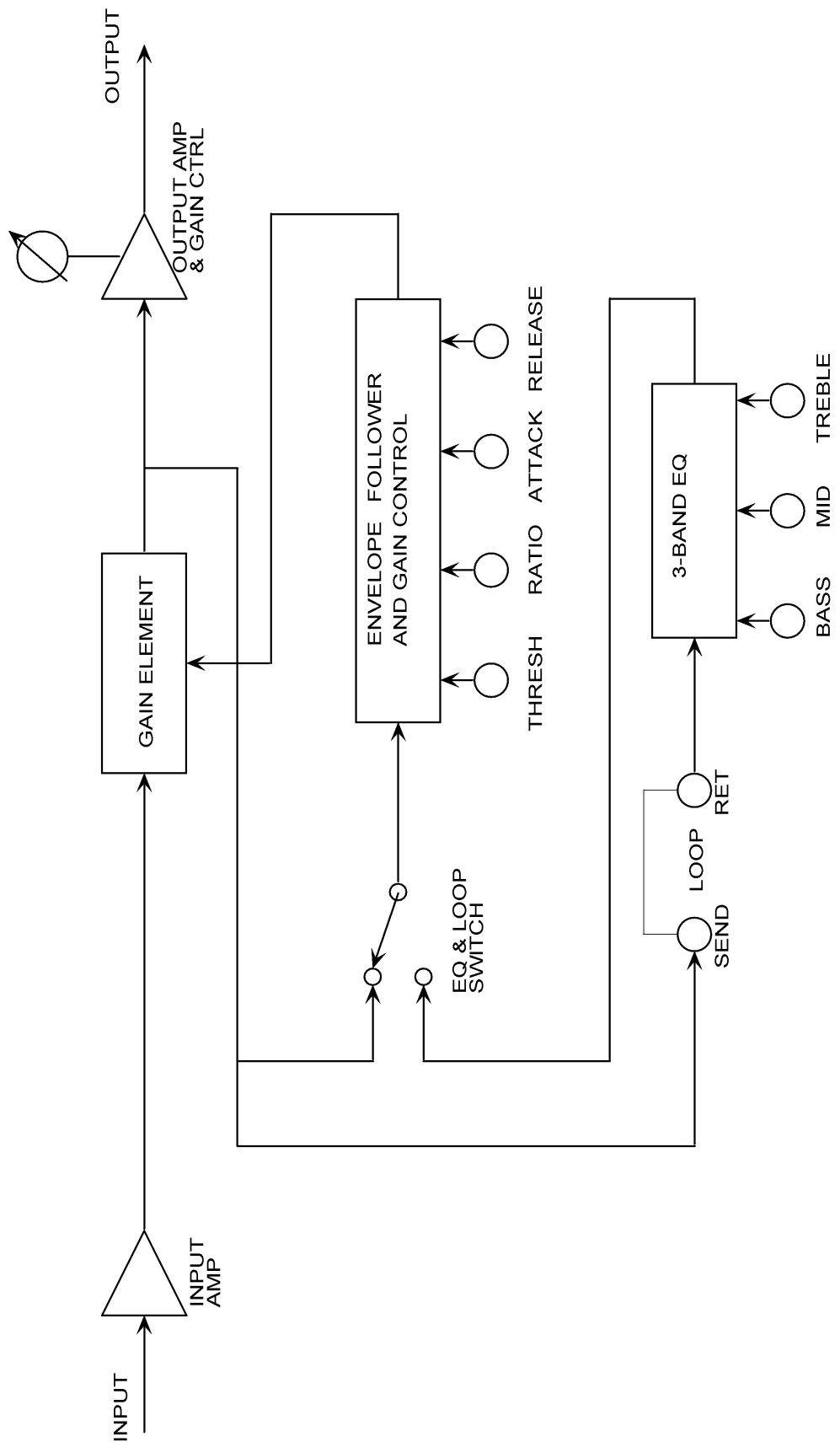

Technical Specifications:

- ATTACK:** 2mS to 150mS
- RELEASE:** 50mS to 1S
- RATIO:** 1.5:1 to 20:1
- THRESHOLD:** -47dBu to ∞
- Make-up GAIN:** 0 to 17dB
- Side-chain EQ Freq:** LOW 30Hz, MID 250Hz, HIGH 2KHz
- Maximum Input:** 11dBu
- Maximum Output:** 11dBu
- Residual Output Noise:** -59dBu from 10Hz-20kHz (un-weighted) with no compression and output gains set to maximum. ****This is the absolute worst case noise scenario.****
- Frequency Response:** 10Hz – 20KHz +0.5/-3dB
- Input Impedance:** 1M ohm
- Output Impedance:** 22K ohm
- Current Consumption:** Approx. 15mA
- Battery Life:** Approx. 30 hours continuous use
- Power adapter (optional):** 9VDC 2.1mm negative center pin

Battery replacement:

Remove the four screws on the bottom cover to access the battery compartment. If storing the unit for long periods of time the battery should be removed to prevent corrosion of the battery snap. Be sure to place the battery wires along the side of the battery in the battery pocket and use care while replacing the bottom cover.

Warranty:

The FEA OPTI-FET Compressor is fully covered for a period of 5 (five) years and the foot switches are covered for 1 (one) year against defects in material and workmanship. Abuse and neglect are not covered under the warranty. The customer will be responsible for shipping cost to and from FEA Labs for repairs. Contact me before attempting to ship a unit for repair at: info@fealabs.com.

All repairs made outside of the warranty period will be very reasonable (usually only the cost of the parts)... your satisfaction is priority one.

Contact FEA Labs at:

Website: www.fealabs.com

Email: info@fealabs.com